



6-4.11.3. Cylinder Borescope Inspection

Regular engine operation provides an oil coating for the cylinder and minimizes rust formation. New cylinders are particularly sensitive to rust formation if the engine is infrequently used or not properly preserved during storage.

NOTE: Ground operation of the engine is an unacceptable substitute for in-flight engine operation. Ground operation does not provide adequate cylinder cooling and introduces water and acids into the lubrication system.

Purpose

The cylinder borescope inspection provides a non-destructive method of visually examining the internal cylinder components and must be used in conjunction with the “Differential Pressure Test” to assess the condition of the valve, piston top, deposits, and the hone pattern on the cylinder barrel and identify abnormal wear patterns which can contribute to low differential pressure readings or increased oil consumption.

The cylinder wall hone pattern consists of engineered surface “scratches” which aid in ring seating by allowing the ring and wall surface to wear uniformly and provides a reservoir of oil for lubrication during ring travel. The cylinder walls and rings are designed to wear over the life of the engine, particularly in the power stroke area. The visible hone pattern in the upper portion of the bore may disappear during normal operation; and is not cause for cylinder replacement.

Required Equipment

- Mechanics tools
- Borescope

Frequency

- During 100-hour/Annual inspection
- If oil consumption is excessive
- After an engine overspeed incident
- Whenever an anomaly is suspected

WARNING

Turn the Ignition Switch OFF and disconnect engine electrical power before commencing maintenance or inspections. Confirm continuity between the magneto capacitor and aircraft ground to prevent accidental engine start during maintenance. Do not stand or place equipment within the arc of the propeller.

Take preventive measures to avoid burns when performing a Cylinder Borescope Inspection on a hot engine.

Procedure

1. Remove the engine cowling as necessary to gain access to the top spark plugs.
2. Remove the top spark plug from each cylinder.



3. Position the piston at bottom dead center on the power stroke. The exhaust valve will be open with the piston in this position.
4. Insert the borescope probe through the upper spark plug hole and inspect the internal surfaces of each cylinder, including the exhaust valve and exhaust valve seat.
5. Position the piston at bottom dead center at the end of the intake stroke.
6. Insert the borescope through the upper spark plug hole and inspect the intake valve and valve seat. Use Table 6-22 and Figure 6-67 through Figure 6-70 to interpret inspection findings.

Table 6-22. Borescope Inspection Objectives and Corrective Actions

Inspection Item	Objective	If Abnormality Noted
Combustion Chamber	Inspect: <ul style="list-style-type: none"> •Valve seat inserts for erosion, burning •Spark plug heli-coils for protrusion into combustion chamber •Heavy carbon deposits/presence of excessive oil 	Remove cylinder for repair
Exhaust Valve Face	Inspect for signs of leakage or damage indicated by: <ul style="list-style-type: none"> •Localized discoloration on the valve face circumference (Figure 6-68) •Minute cracks •Erosion (missing material) 	Repair or replace cylinder
Intake Valve Face	Inspect for signs of leakage or damage indicated by: <ul style="list-style-type: none"> •Localized discoloration on the valve face circumference •Erosion (missing material) 	Repair or replace cylinder
Cylinder Bore	Inspect exposed surface of bore for: <ul style="list-style-type: none"> •Heavy scoring/piston rub (Figure 6-71) •Piston pin rub (wide band pattern in horizontal plane at 3 o'clock and/or 9 o'clock position) 	Repair or replace cylinder
	Corrosion (Figure 6-70) ¹ Excessive oil in cylinder/heavy deposits of carbon in combustion chamber	Remove cylinder for repair
	Upper portion of cylinder bore has no visible hone pattern (Figure 6-72) and (Figure 6-73)	Normal indication for in service cylinders
Piston Head	Inspect for: <ul style="list-style-type: none"> •Piston crown for erosion, missing material •Visible damage from foreign debris 	Remove cylinder for repair

1. Remove cylinder for repair or replacement. Perform complete inspection of connecting rod bushing for correct installation and finishing.



Figure 6-67. Normal Combustion Chamber

Exhaust valve has reddish deposit in center with dark outer edge. Intake valve has light brown combustion deposits. Combustion chamber has light brown deposits.



Figure 6-68. Burned Exhaust Valve

Note the edge of valve face has lost all combustion residue with striations moving toward center of valve.



Figure 6-69. Phosphate-Coated Cylinder w/ Revised Hone Pattern

Phosphate coating provides increased corrosion protection during initial hours of engine operation.



Figure 6-70. Phosphated Cylinder Bore

Phosphate coating in valleys of the cylinder bore hone pattern. Light corrosion at top of cylinder bore, above piston ring travel limit in this area is normal.

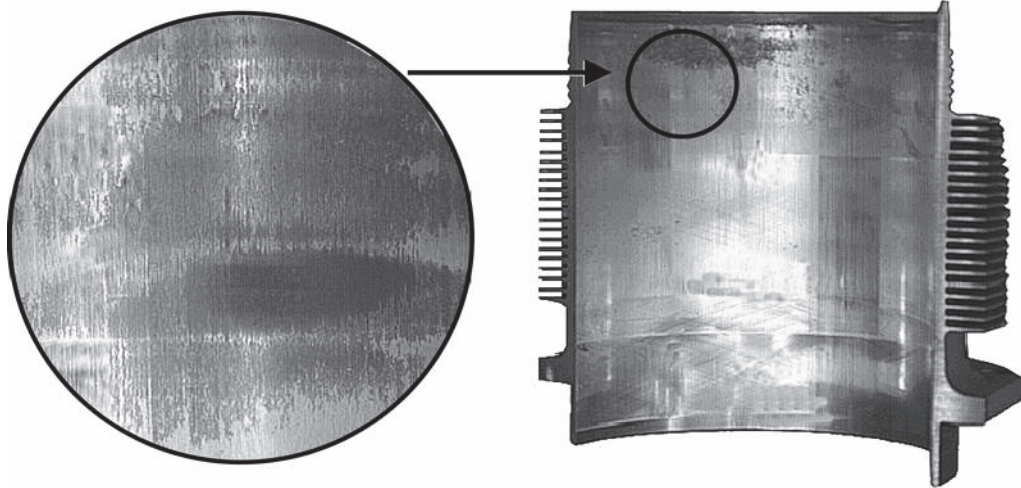

Figure 6-71. Cylinder Barrel Scoring and Piston Rub

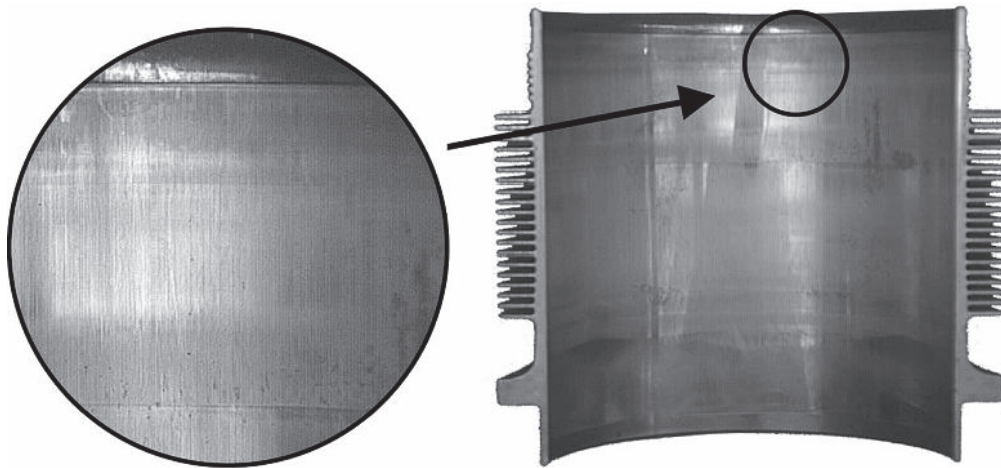

Figure 6-72. Typical Wear in Upper Ring Travel

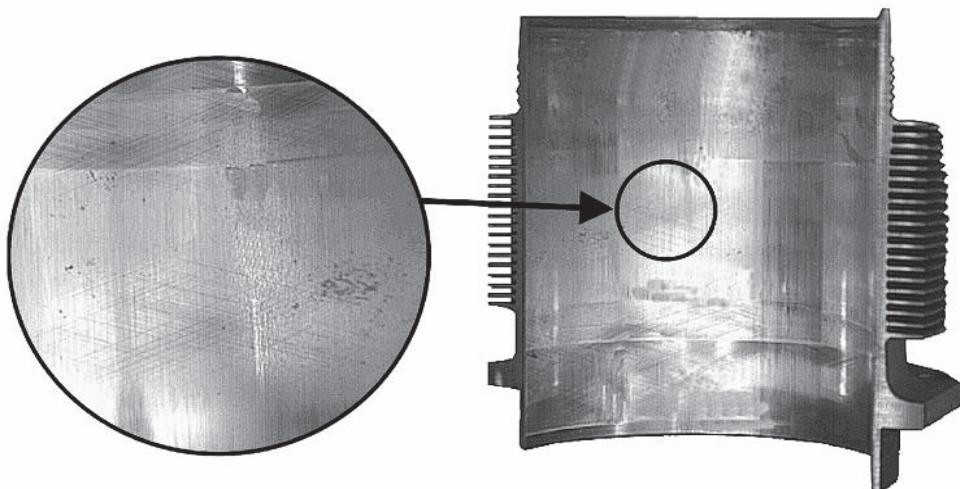

Figure 6-73. Typical Cylinder Wear